

# **Thermal Biomass Gasification in Denmark**

## **IEA Bioenergy Task 33**

First semi-annual task meeting  
Golden, Colorado, 6-9 May 2013

M.Sc. Morten Tony Hansen  
Senior Project Manager  
FORCE Technology – Industrial Processes

- Update on Danish gasification plants and projects
- Trends in the Danish framework conditions

- FIRgas Alternating Gasifier
  - Twin bed filter
  - Aiming at straw
- Technology now under development by B&W Vølund
- Pilot plant 400 kW<sub>th</sub>
  - Wood chips
  - In weekly operation
- Application not yet clear
  - Fuel likely, not IC engine
  - Gas composition high on H<sub>2</sub> and CO, no N<sub>2</sub>, low CO<sub>2</sub>

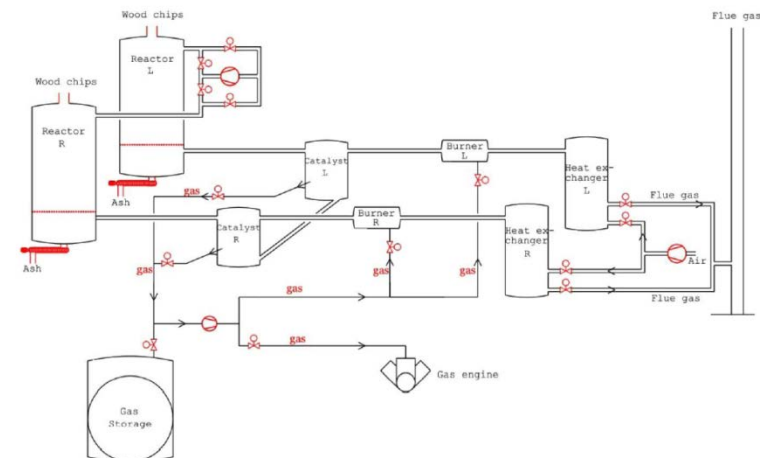

- 20 years gasifier operation
  - CHP operation for 12 years
  - 650 kW<sub>e</sub>
- Tar challenge turned into flexibility advantage
- Need for new demo plant
- Home market challenges:
  - Feed in tariff not designed for CHP
  - DH plant managers prefer simple heating plants
- Foreign markets:
  - Promising tariffs but heat of low value



# Biosynergi – Hillerød Plant



- Open core downdraft for CHP
- Years of careful pilot plant operation North of Copenhagen
- New demonstration plant under construction in Hillerød
  - 300 kW<sub>e</sub>
  - wood chips
- Status
  - Building in place
  - Large hardware in place
  - Assembly ongoing
- Expect operation in 2013



# Weiss Viking plant in Hillerød

- Staged down draft for CHP
- Developed by DTU/COWI
- New 600 kW<sub>e</sub> wood chips based demonstration plant started up in Hillerød November 2012
- Encountered various start up problems - taking half a year
- Expecting continuous operation very soon.



- Low temperature CFB
  - Developed by Peder Stoholm/DTU
- Pilot plant in Kalundborg
  - 6 MW<sub>th</sub>
  - Loose straw
  - Gas co-fired into coal boiler
  - Operated on various fuels
  - Operated for design of large demo
- 50 MW demonstration plant
  - Expected operational in 2015



# EP Engineering Plant in Herlufsholm



- Vibrating grate FB
  - Gas fired into steam boiler
  - Steam engine for CHP
- Plant ready
  - 200 kW<sub>th</sub> wood chips
  - 100 bar/500°C
- Financial challenges
- Owner employed elsewhere
- Host no longer patient
- Operation expected

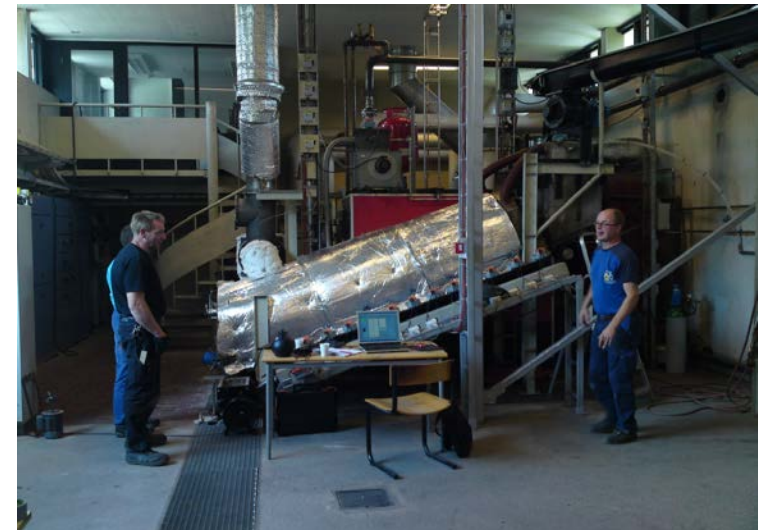



# Frichs Sublimator Plant

- Pyrolysis/biochar CHP unit
  - Straw fed
- Gasifier concept purchased
- Aims to gasify manure fibre
- Plant installed at farm
- No gas filtering/cleaning
- 
- 
- 
- 
- Currently not in operation

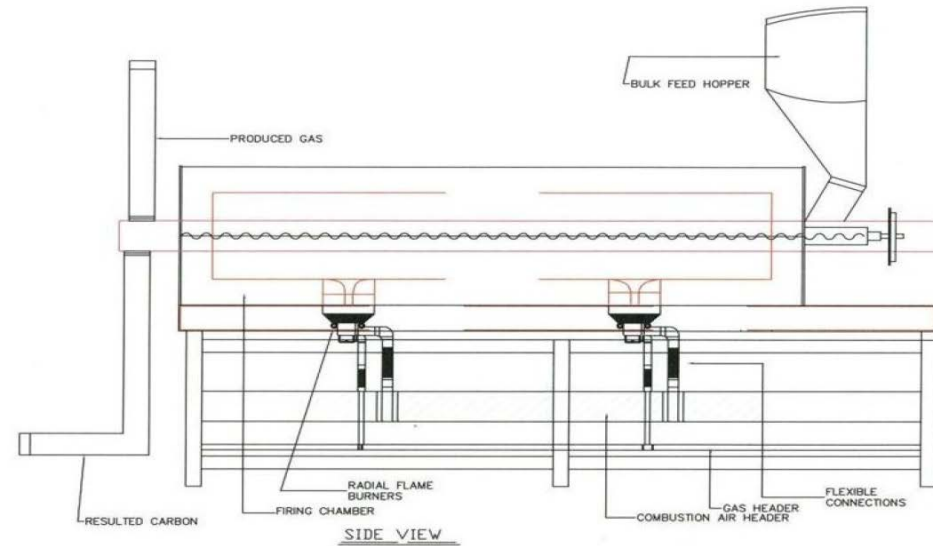

- Catalytic LT Pyrolysis
- Straw for oil and gas (-> CHP)
- 29% oil - 20% gas
- New plant in Ødum
  - Expected operational in Q2 2013
- Supported from DEA/EUDP



# Stirling DK

- Biomass fired Stirling engine developed for 20 years
- Updraft forest chips gasifier
- >10 plants in operation
- New engine in design phase
  
- Bankrupt during spring 2013
- Employees released
- Assets for sale/sold

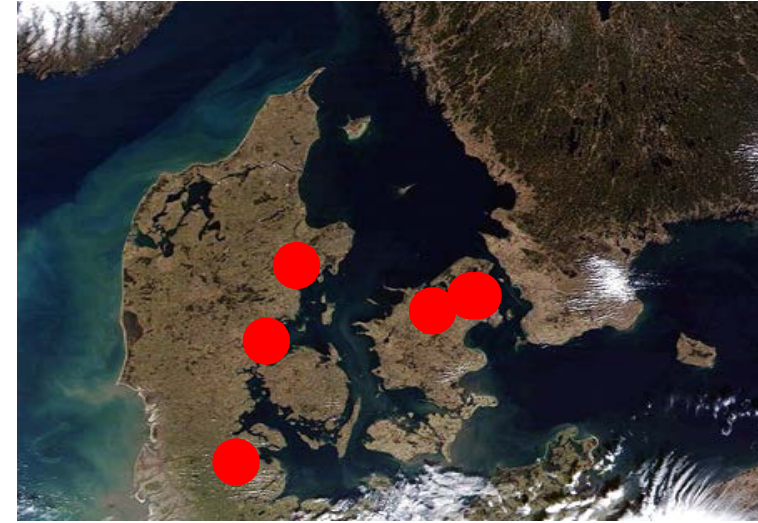

# Carbona plant in Skive



- Europe's largest CHP
  - 6 MW<sub>e</sub>
  - wood pellet fuelled
  - pressurized CFB
- Co-financed by the US DOE
- Stable operation from 2012:
  - Available 70% of the time due to
    - New filters
    - New catalyst
    - Improved fuel quality + additive
- Liquid fuel generation tested
  - Tigas process from Haldor Topsøe



Photo courtesy of C.F. Møller, foto by Ole Hein Petersen

- DALL Energy
  - Idea to proceed with gasification from successful furnace
- FLSmidth
  - Pilot plant in operation at test site
- Frichs - 1RGI - Gasification.dk
  - Project on optimised updraft gasifier/IC engine system
- GGC-TECH
  - Developing micro scale gasifier/gasturbine system
- TK Energy
  - TK Energi bankrupt January 2013, started over as TK Energy

- Universities
  - Biomass Gasification Group at DTU/Risø has merged with DTU Chemical Engineering (CHEC)
- Advanced Technology Group
  - Danish Technological Institute (DTI)
  - FORCE Technology
- Consultants
  - Danish Gas Technology Centre (DGC)
  - Aaen Consulting Engineers
  - COWI

- "New" government increased green targets
  - 2020: Half of electricity demand covered by wind
  - 2030: No coal at power plants, no oil heating
  - 2035: Electricity and heating fully covered by RE
  - 2050: Complete energy supply fossil free
- Energy agreement
  - Comprehensive biomass analysis ongoing
  - Energy plan later in 2013
- Current feed-in tarif: 15 €/kWh
  - Currently for approval by EC
  - Related to natural gas price



# A vision for the energy system in 2050

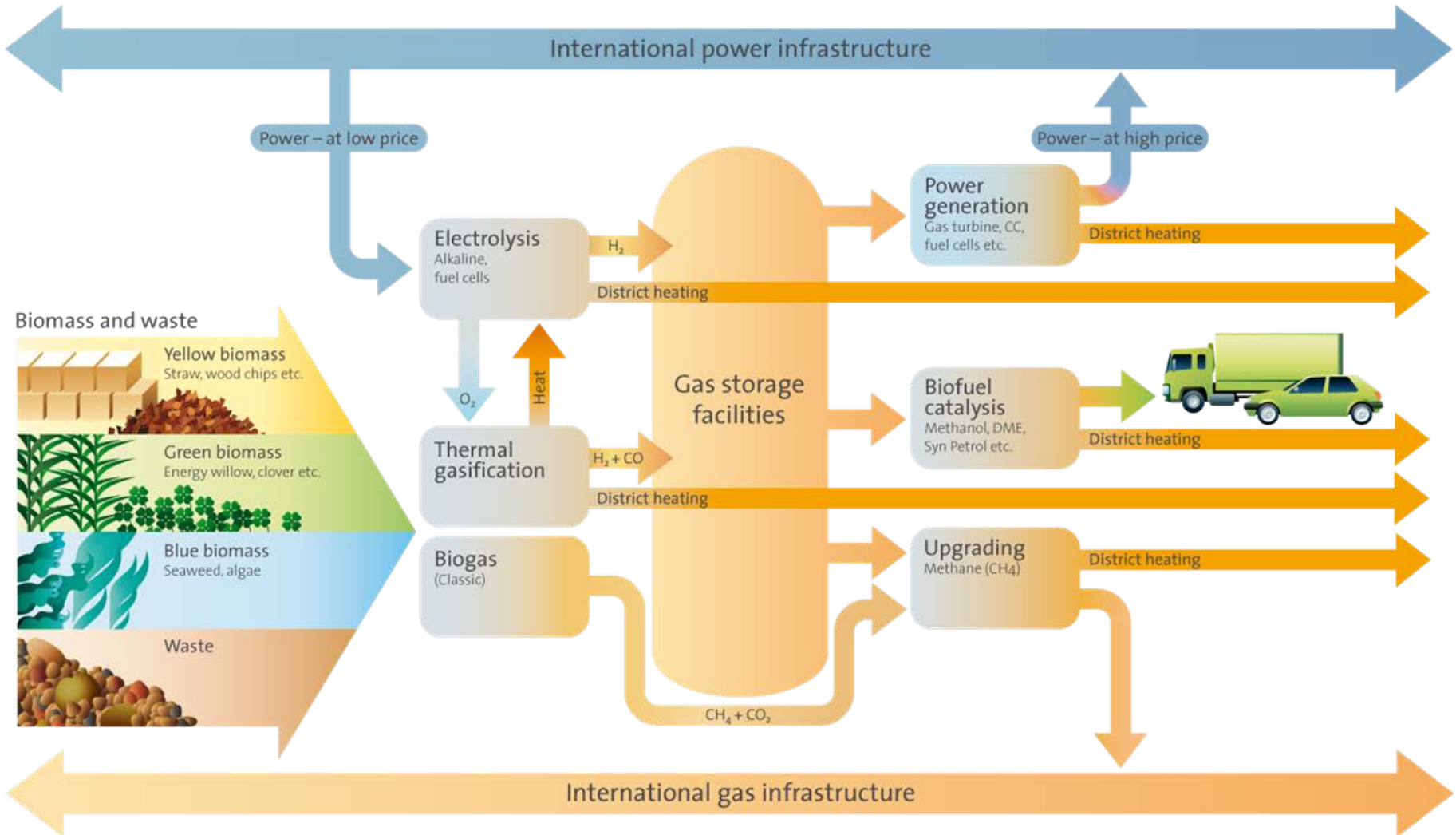



# A vision for the energy system in 2050 (2)

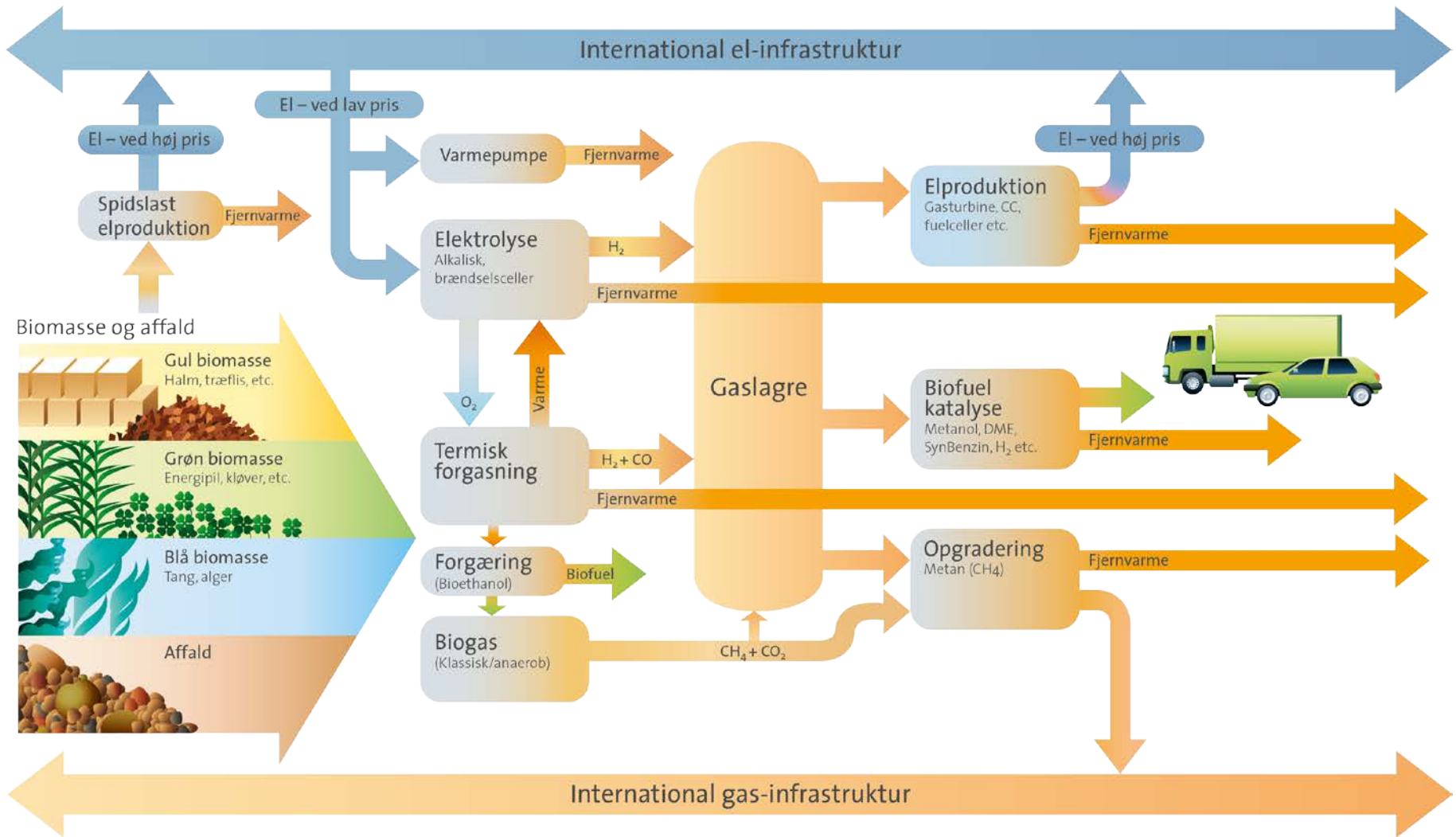

A photograph of a wood processing site. On the left, there is a large stack of cut logs. On the right, there is a large pile of wood chips. A dirt path leads from the logs towards the wood chips. The sky is blue with some clouds.

Thank you!

M.Sc. Morten Tony Hansen - FORCE Technology - T: +45 7215 7700 - E: [mth@force.dk](mailto:mth@force.dk)  
[www.forcetechnology.com](http://www.forcetechnology.com)