

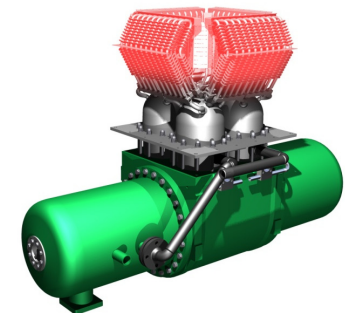

Gasification in Stirling Engine Applications

October 2010

STIRLINGDK
Clean Power Production



Stirling DK's Value Proposition

Conversion of Low-value Biomass, Biofuel, and Gas Into High-value, Distributed (35-500 kWe) Clean Electricity and Heat



Stirling DK CHP Plant



Biomass



Biofuel



Direct Combustion or Gasification of Biomass



District Heating or Heating for Industrial Purposes

Electrical Power For Grid or Local Use

Stirling Engine Vs. Diesel Engine

Fuelled by External Heat Source

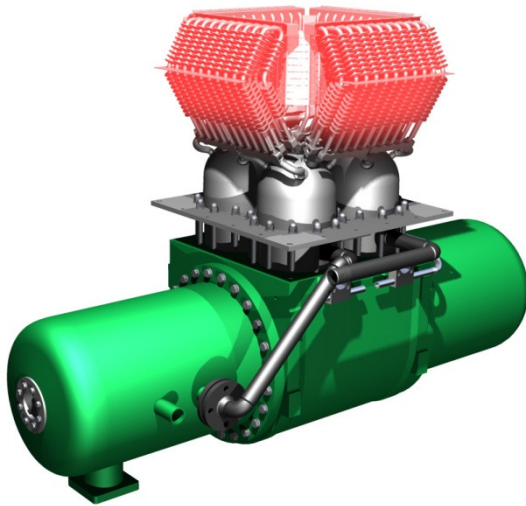

Stirling Engine Principle

Engine Driven by External Heat Source

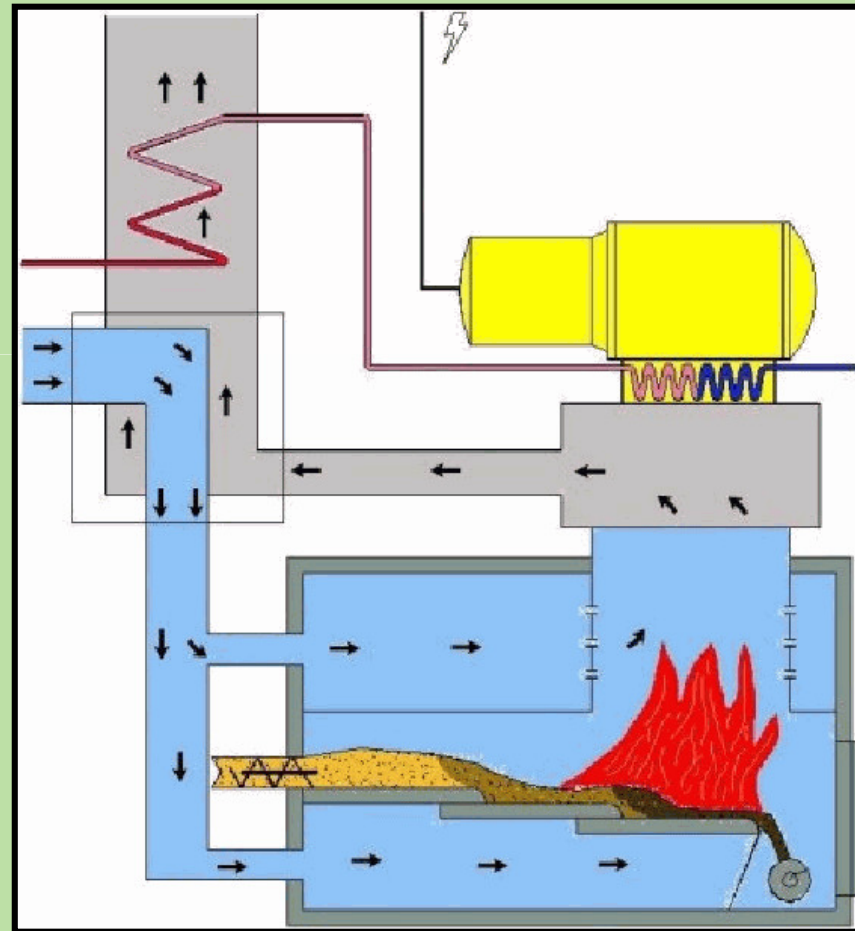

Historic Development of Stirling DK

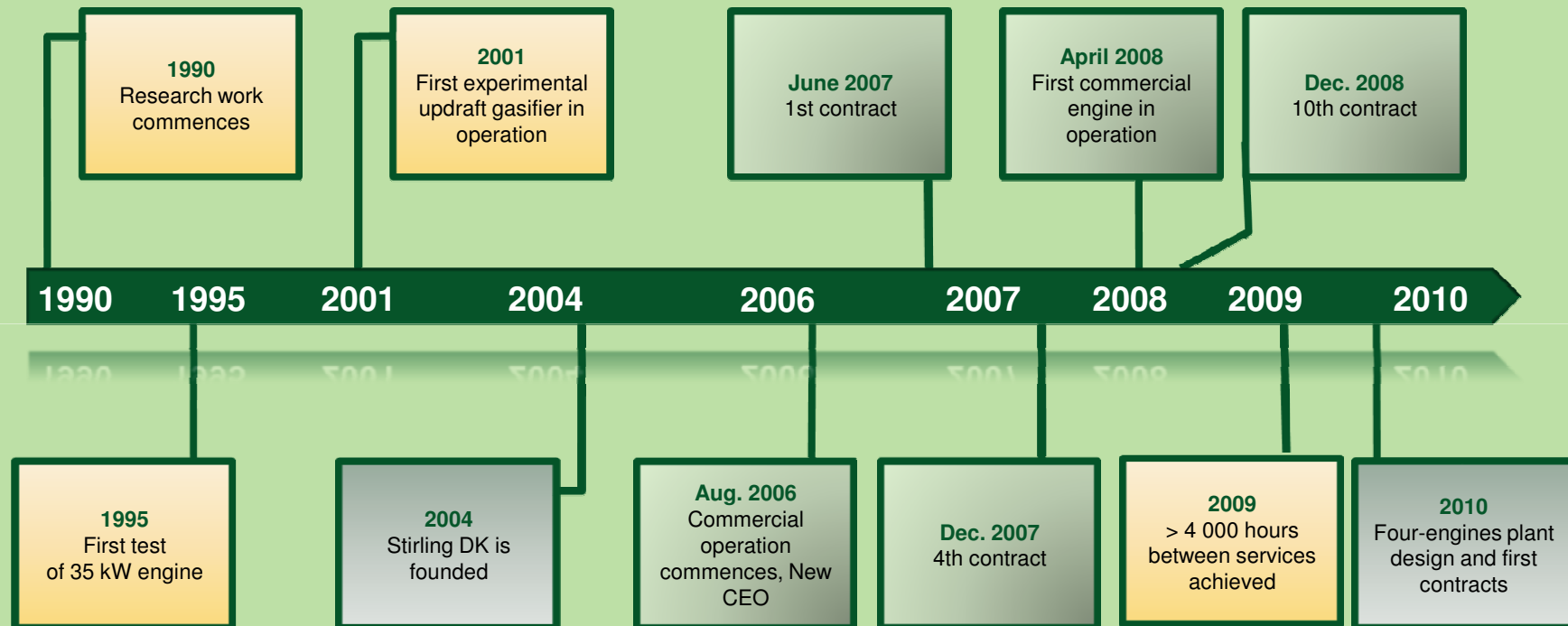

Company is Owned by German and Danish Investors, including RWE Innogy and the Growth Foundation, and the Founder Group

Technology Fills a Market Gap

Technology Unique for Distributed CHP Production



The market potential in Europe is several billions of Eur per annum and a significant technology gap exists:

”The market for sub 1 MW biomass CHP technology could be worth over half a billion pounds per annum from 2016 if technological and supply capacity constraints are overcome. Biomass CHP on this scale is not currently commercially mature, though pre-commercial trials are underway”

ref. Report by the UK Renewables Advisory Board
www.renewables-advisory-board.org.uk, 2009



Product Portfolio

3 Product Configurations Serving Differentiated Market Needs



Stand-alone Engine

- Stirling Engine
- Interface
- Control system

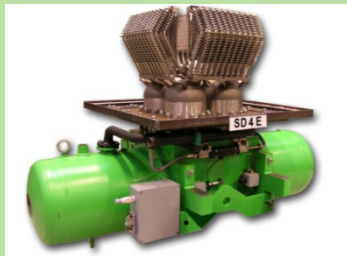
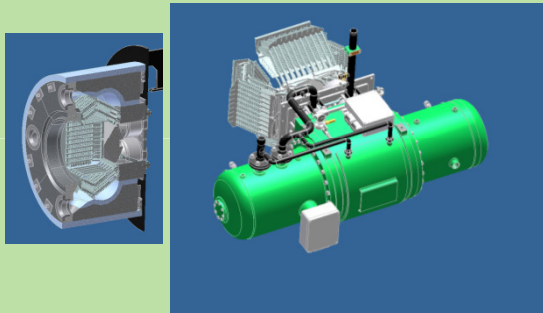

OEM delivery to boiler manufacturers

Engine with CoC

- Stirling engine
- Combustion Chamber
- Burner System
- Control system

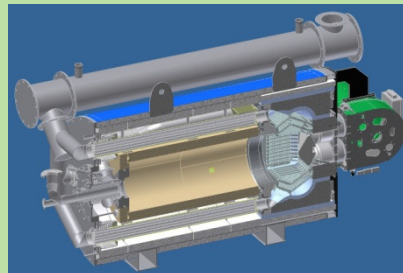
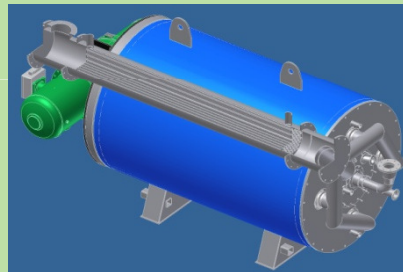

OEM delivery to producers of gasifiers, biogas, landfill gas systems, etc.

CHP Plant

- Engine with CoC
- Updraft Gasifier
- Plant Control system
- Interfaces to end user



OEM delivery to contractors

Stand-alone Engines

Solution for Direct Combustion



- 5 engines installed on Wood Chips Boilers
- Totally around 40,000 hours of operation clocked
- Engine availability above 95%



Engine with Combustion Chamber



E.g. Pyrolysis Oil,
By-products from biofuel production,
Low energy content gas

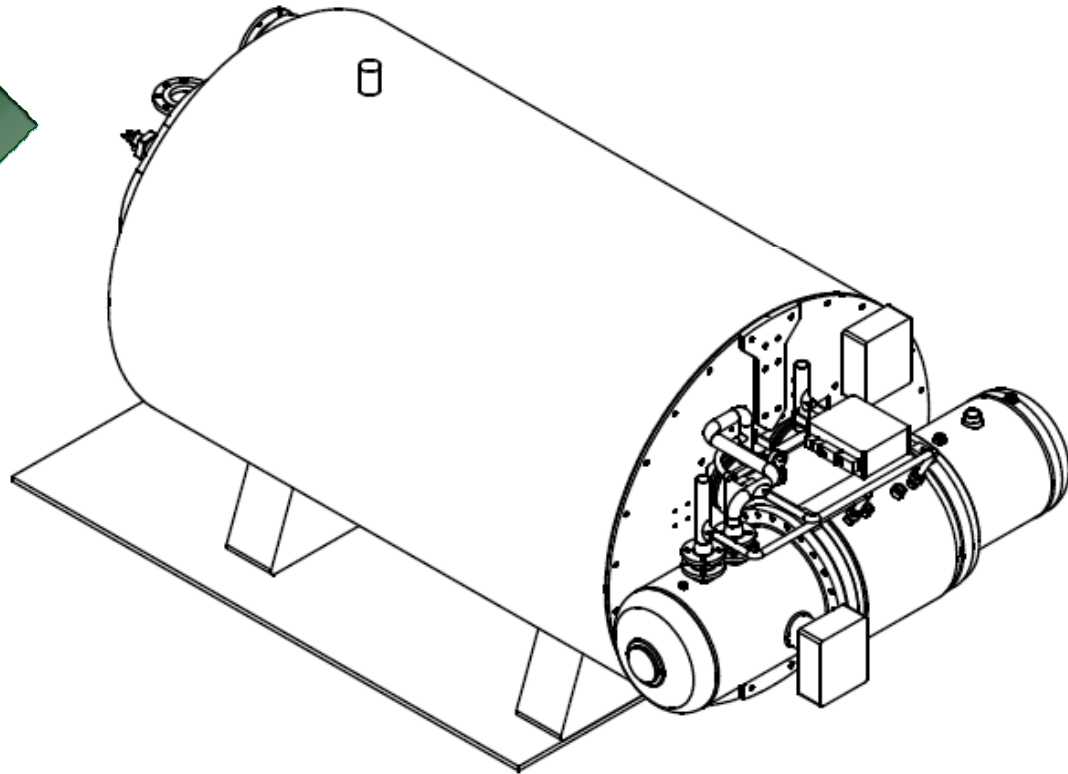

Gasification and Stirling Engine

Updraft Gasifier and Stirling Engine

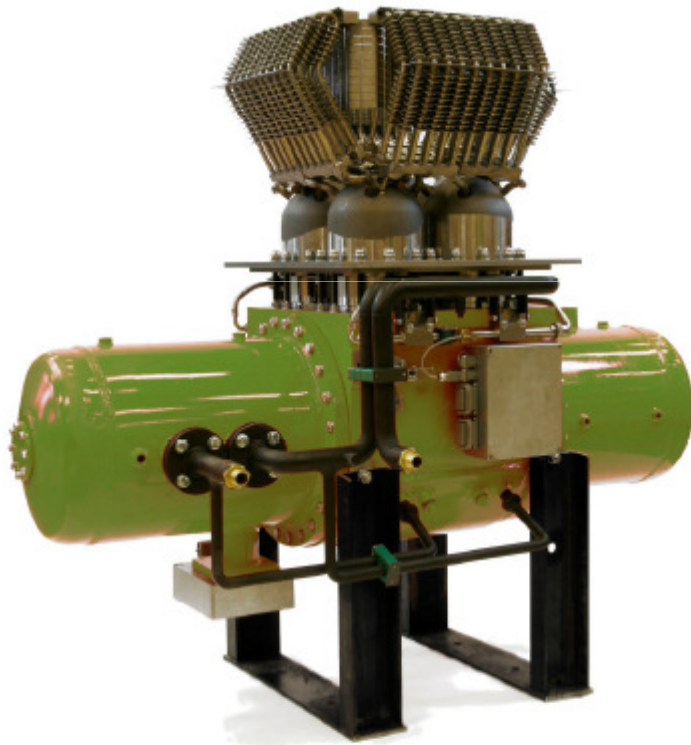

35 kW Stirling engine



200 kW
updraft gasifier

Gasification and Stirling Engine

Process Diagram for 1-Engine Plant

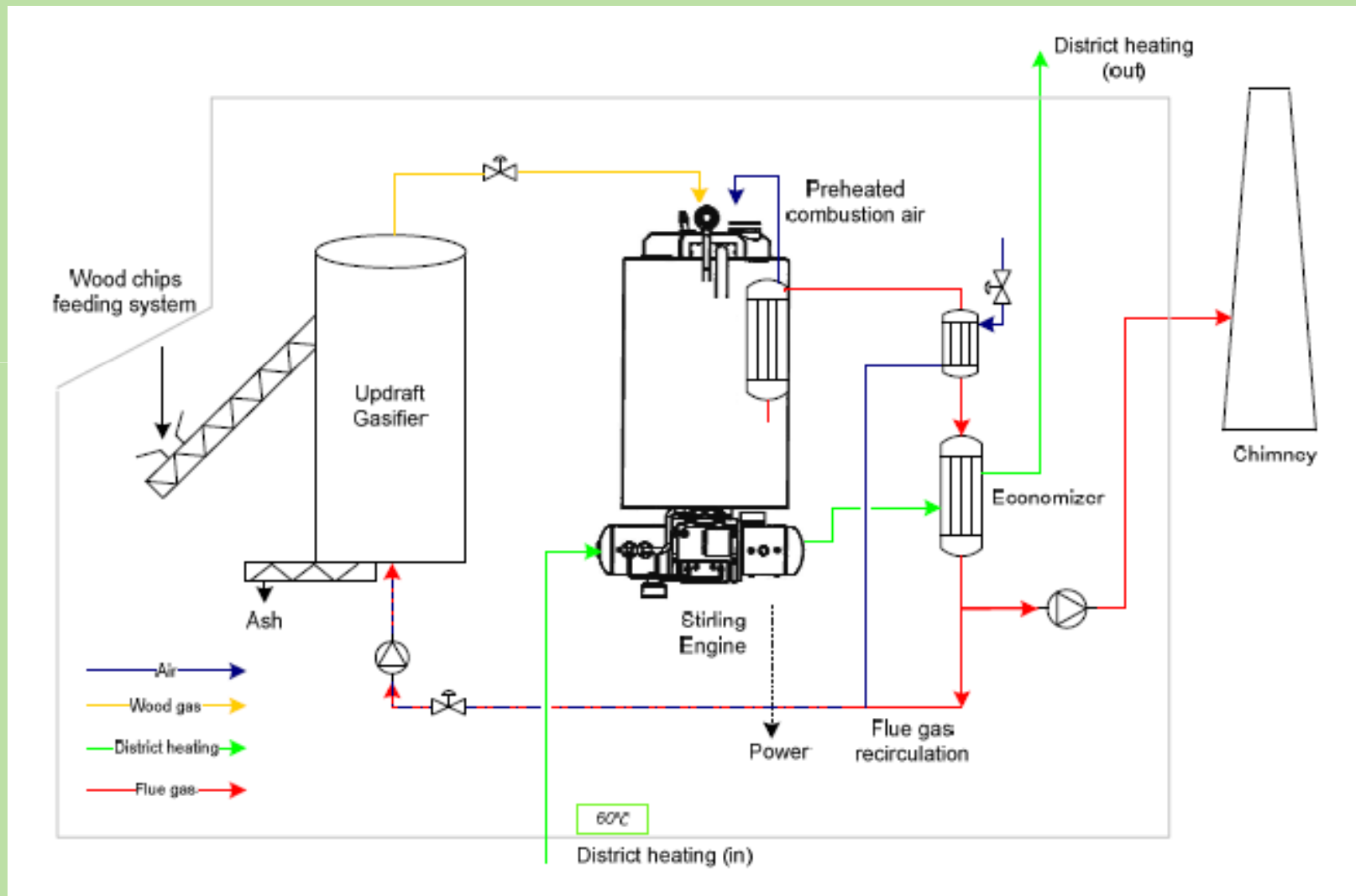

Gasification and Stirling Engine

Gasification of Wood Chips

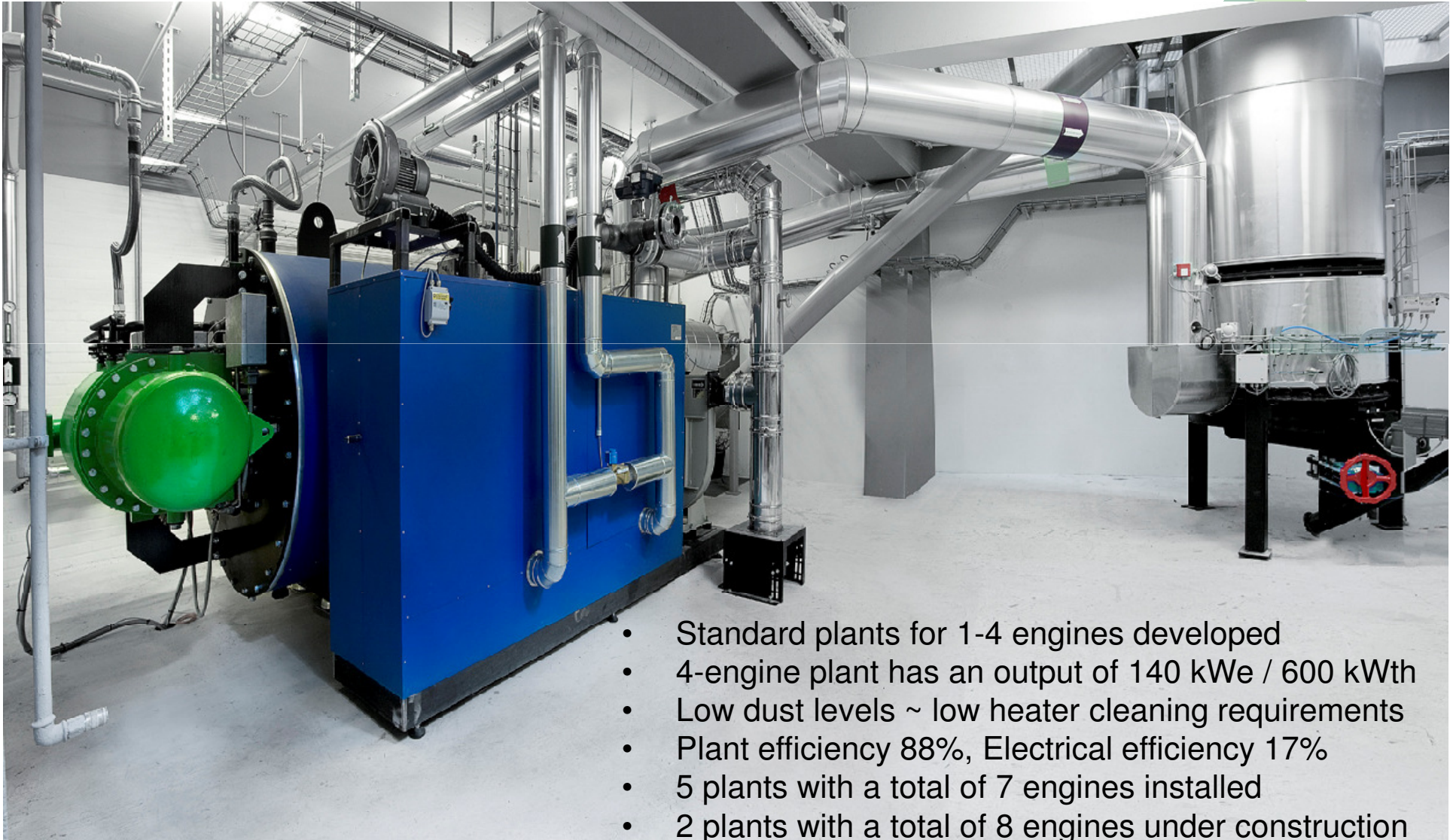

- Standard plants for 1-4 engines developed
- 4-engine plant has an output of 140 kWe / 600 kWth
- Low dust levels ~ low heater cleaning requirements
- Plant efficiency 88%, Electrical efficiency 17%
- 5 plants with a total of 7 engines installed
- 2 plants with a total of 8 engines under construction

Gasification and Stirling Engine

2-engine 70 kWe / 280 kWth Plant for Hospital in Hannover



13



Gasification and Stirling Engine

Containerized One-engine Plant in Copenhagen



- Allows production under factory conditions and easy "plug-and-play" installation
- Built into three (3) standard 20' ship containers
- One additional fuel storage container

Gasification and Stirling Engine

Two Identical Four-engine Installations (140 kW_e / 600 kW_{th})
Under Construction



15

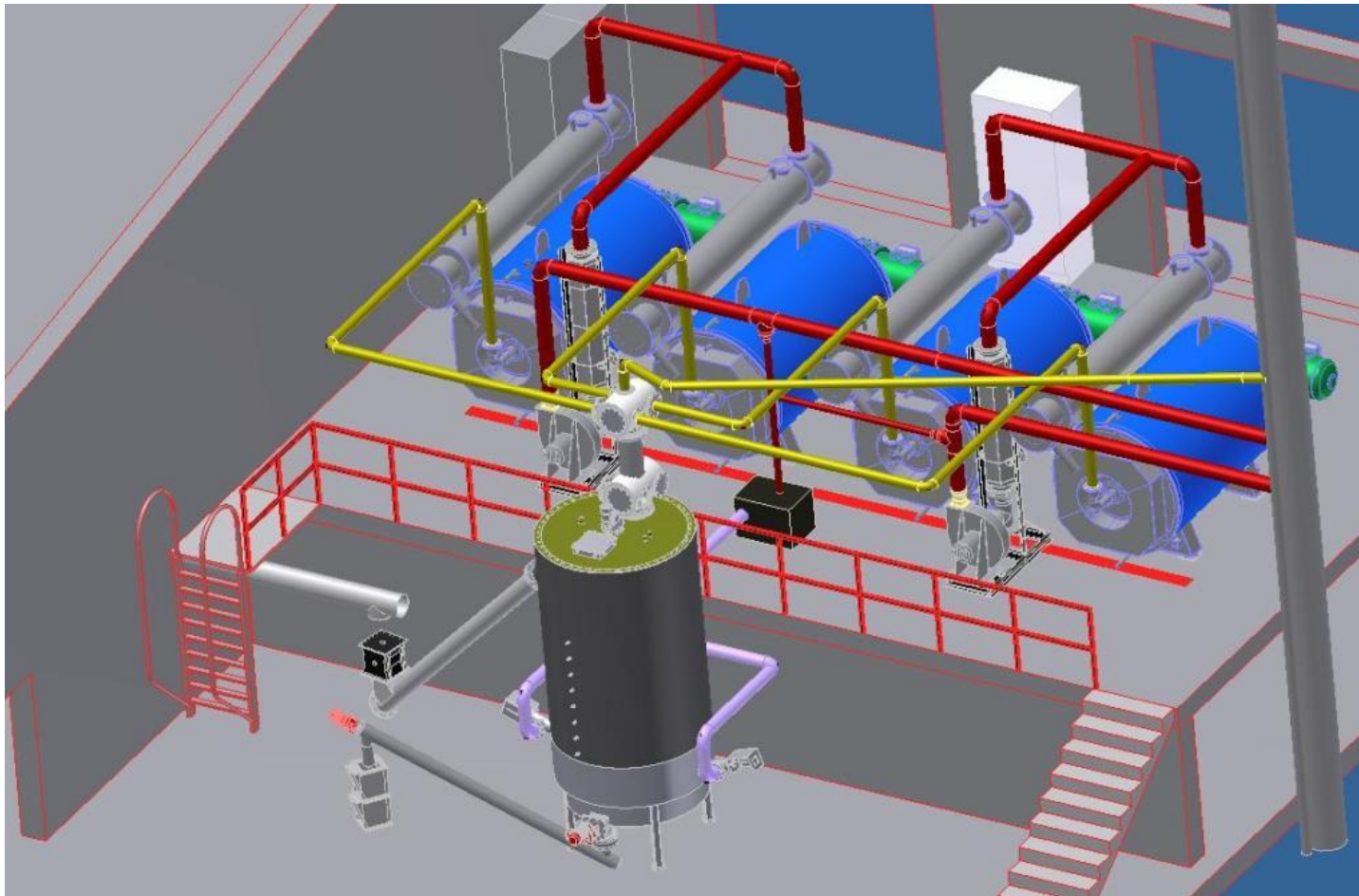

Gasification and Stirling Engine

Case Study: Four-engine Installation in Germany



Investment for End-customer

- Cost of plant equipment ~ 1,000,000 EUR (Stirling DK's delivery scope)
- Other project costs (including project management, civil works, erection, etc.) ~ 400,000 EUR
- Total project costs 1.4 million EUR

Plant Economy for Customer

- Fuel input: 800 kW
- Energy output: 140 kW_e and 600 kW_{th}
- Self-consumption: 10 kW_e
- Annual operating hours: 7,000
- Yearly energy production: 910,000 kW_e and 4.2 GW_{th}
- Value of energy: 26,67 Cent/kWh power, 4 Cent/kWh heat
- Total yearly revenue: ~ 410,000 EUR
- Fuel cost: ~ 2.0 Cent/kWh
- Total fuel costs: 112,000 EUR/year
- Service and maintenance costs: ~ 2.5 Cent/kWh power plus 0.5 Cent kWh heat
- Total service, and maintenance costs: ~ 45,000 EUR
- Total contribution: 253,000 EUR/year ~ 5.5 years' payback time

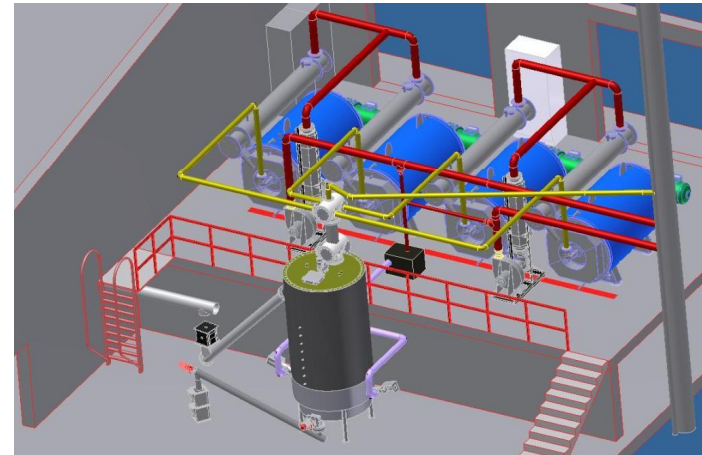

Pyrolysator and Stirling Engine

Production of Clean Power, Heat, and Bio-Char



Biochar used as a natural fertilizer by
Denmarks' leading ecologic estate



Contact Information:

CEO Dr. Lars Jagd

Tel +45 88 18 48 00

Fax +45 88 18 48 80

Cell +45 22 16 33 87

Mail lkj@stirling.dk

Web www.stirling.dk



STIRLINGDK

Clean Power Production